

EF 206 *XSafe*

Self Contained Ice Machine 200 kg

Item #:
Project:
Quantity:



FEATURES

- Produces granular shape ice flakes, 80% hardness. Ice scoop holder safely positioned in ice-storage bin.
- Resistant stainless steel exterior.
- Advanced diagnostics computerized control.
- Front panel in & out airflow (air-cooled model only) for built-in installation.
- Front access condenser air filter, removable and washable (air cooled version only). Easy, front panel access to technical / service area of the machine.
- Easily accessible, front panel mount, ON-OFF Switch.
- Ergonomically designed ice storage access, with disappearing door. Door-closing movement dampening system.
- PWD - Progressive Water Discharge: pumps excess residual water up to a distance of 15 meters.
- XSafe: natural sanitation system, integrated inside the ice maker and operating automatically 24/7 to keep equipment clean & safe.



EF 206
Flake ice
Residual water content 25%

CONDENSING SYSTEM

Air cooled
Water cooled

REFRIGERANT GAS

R134a

INTERNAL BIN CAPACITY

60 kg

VOLTAGE V/Hz/ph

230/50/1

CERTIFICATIONS



OPERATING REQUIREMENTS

	Minimum	Maximum
Air temperature	10	43
Water temperature	5	38
Water pressure	1 bar (14 psi)	5 bar (70 psi)
Electrical voltage	-10%	+10%

IMPORTANT NOTICE:
Models and specifications are subject to change without notice.
This spec sheet is meant for commercial purpose only.
For technical documentation please refer to our service manuals.

Self Contained Ice Machine 200 kg

EF 206 XSafe

Self Contained Ice Machine 200 kg

Item #:
Project:
Quantity:

Self Contained Ice Machine 200 kg

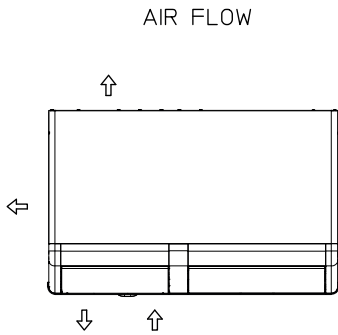
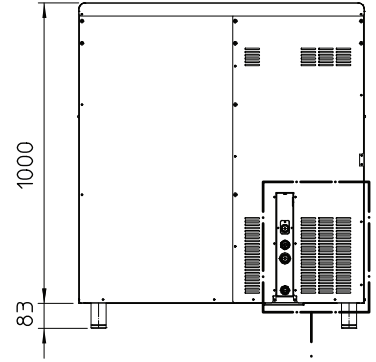
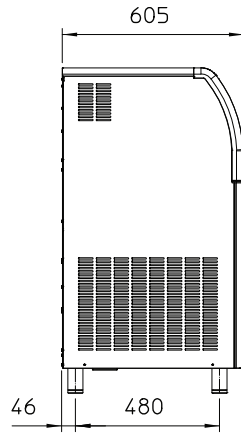
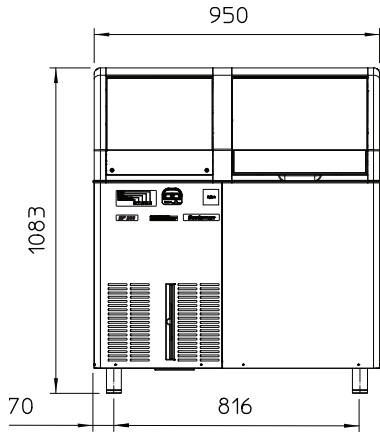

- UNIT OF MEASUREMENT: mm
- 25/32" - OVERFLOW DRAIN
 - 3/4" GAS - WATER INLET
 - 3/4" GAS - WATER OUTLET
WATER COOLED UNIT ONLY
 - 3/4" GAS - WATER INLET
WATER COOLED UNIT ONLY
 - CORD SET

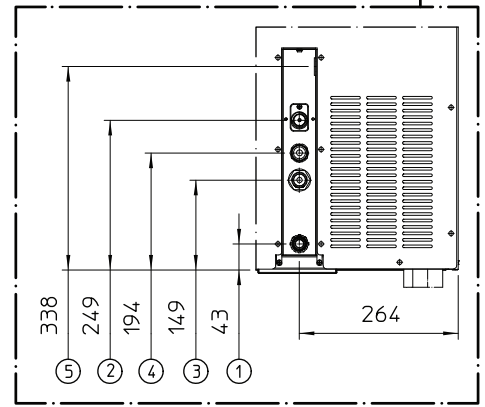

UNIT DATA		SHIPPING DATA									
Size (W x D x H)	950 x 605 x 1083 mm	Carton (W x D x H)	1030 x 680 x 1170 mm								
Net weight	79 kg	Weight	92 kg								
		24 h ice production kg °C Amb. / °C Water			Energy consumption (*)		Water usage (*)	Instant power	Compressor	Circuit wires	Max. fuse size
Version	Voltage	10°C/10°C	21°C/10°C	32°C/21°C	kWh/100 kg	kWh/24h	l/h	W	W	No. x Ømm²	A
EF 206 AS	230/50/1	200	195	155	13.2	20.5	7.0	950	3400	3 x 1.5	10
EF 206 WS	230/50/1	205	200	178	10.7	19.0	68.0	800	3400	3 x 1.5	10

(*) Data refer to 32°C Amb. / 21°C Water temperature conditions



WolfLabs

Pricing on any accessories shown can be found by keying the part number into the search box on our website.

The specifications listed in this brochure are subject to change by the manufacturer and therefore cannot be guaranteed to be correct. If there are aspects of the specification that must be guaranteed, please provide these to our sales team so that details can be confirmed.

www.wolflabs.co.uk

Tel : 01759 301142

Fax : 01759 301143

sales@wolflabs.co.uk

Please contact us if this literature doesn't answer all your questions.